

REVISIONS		
ISS	DESCRIPTION	DATE

RoHS COMPLIANT

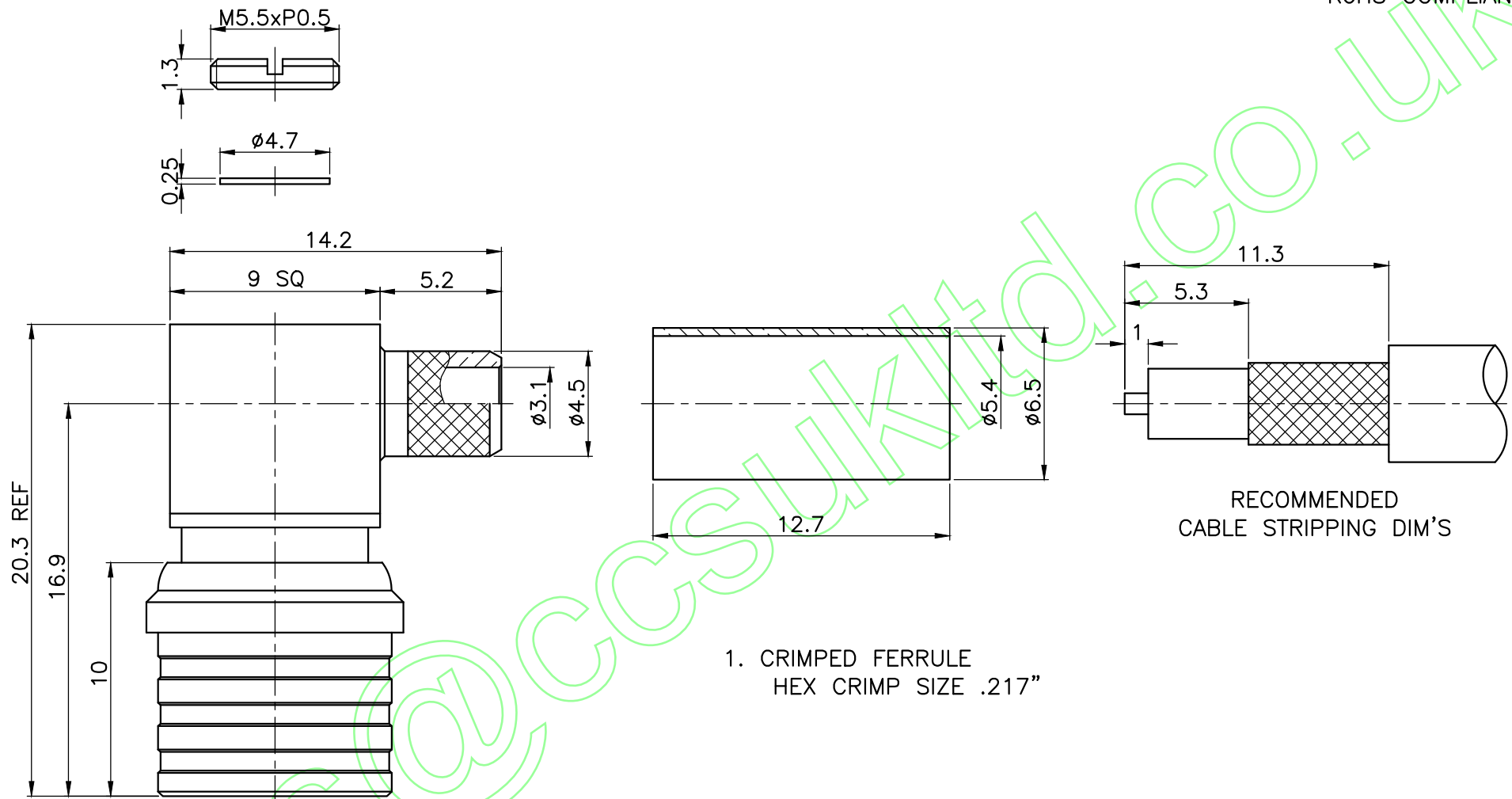

1. CRIMPED FERRULE
HEX CRIMP SIZE .217"



TITLE: QMA MALE RIGHT ANGLE CRIMP
(FOR RG58)

PART NO: QLAPRACR58

DRAWING NO: 055

APRD: _____

CHKD: _____

DR: _____

DATE: 08/28/18" UNIT: mm

SHEET: . SCALE: 4/1

UNLESS OTHERWISE SPECIFIED TOLERANCES

0.5-6 = ±0.2

>6-30 = ±0.4

>30-120 = ±0.6

>120-315 = ±1

>315-1000 = ±1.6

ANGLES = ±5°

NO.	DESCRIPTION	MATERIAL	FINISH
	O RING	SILICONE	RED
	FERRULE	BRASS	NICKEL
	SHELL	BRASS	NICKEL
	PRESS BODY	BRASS	NICKEL
	BODY	BRASS	NICKEL
	INSULATOR	TEFLON	WHITE
	CONTACT PIN	BRASS	GOLD
	CABLE BODY	BRASS	NICKEL
	INSULATOR COVER	DELTRIN	
	PRESS WASHER	BRASS	NICKEL